

Vibration plate / Vibrationsplatte

VP275

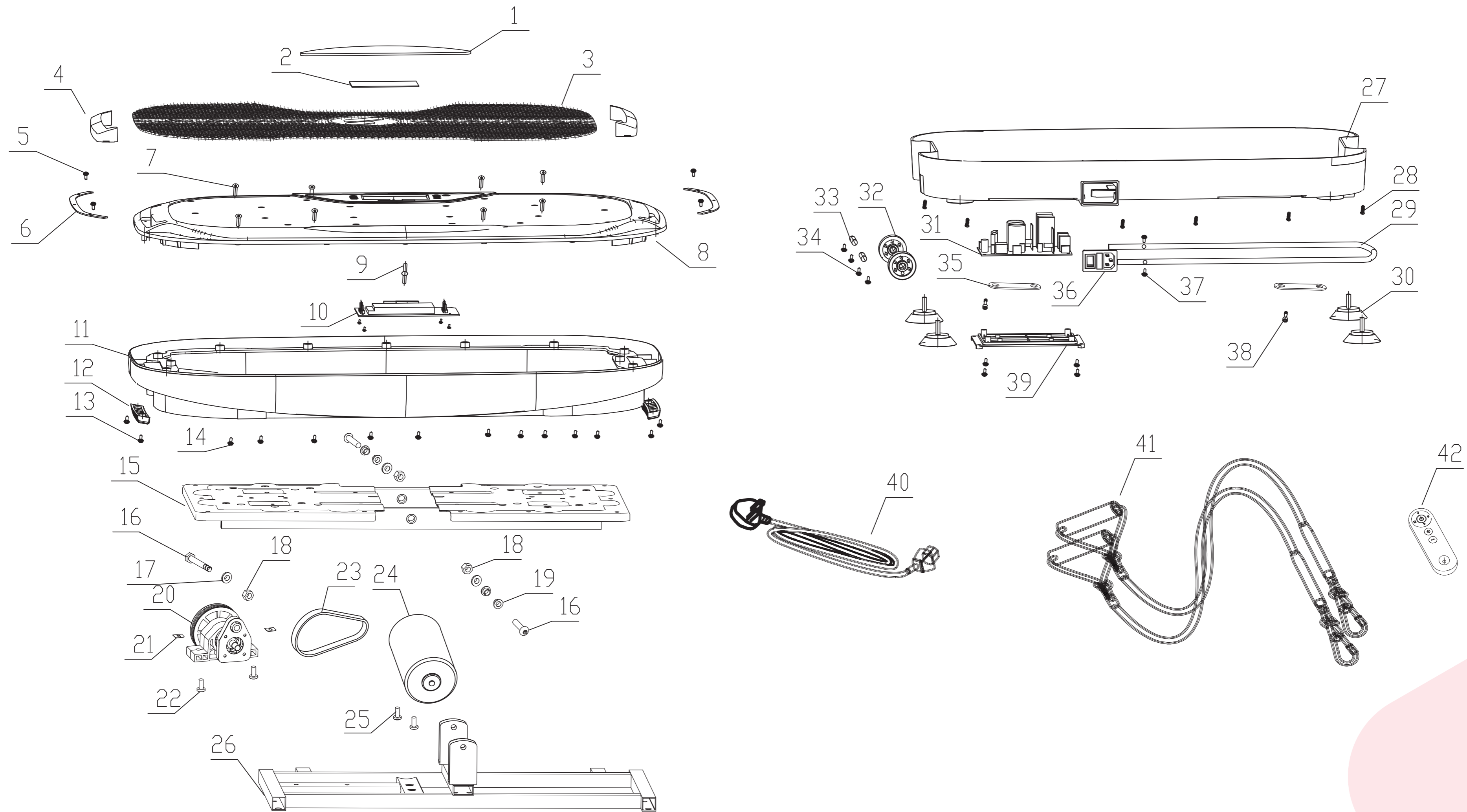

**EXPLOSION-DRAWING /
EXPLOSIONSZEICHNUNG**

SPAREPARTS-OVERVIEW / ERSATZTEILLISTE

No. in explosion drawing	Item No.	Description English
1	SP_VP275_01	Overlay
2	SP_VP275_02	Screen protection plate
3	SP_VP275_03	Mat
4	SP_VP275_04	LED strip cover
5	SP_VP275_05	Cross recessed oval head tapping screw ST3x8
6	SP_VP275_06	LED strip
7	SP_VP275_07	Truss head screw M5x10
8	SP_VP275_08	Upper housing
9	SP_VP275_09	Positioning rob
10	SP_VP275_10	Display board
11	SP_VP275_11	Middle housing
12	SP_VP275_12	Anti-touching cushion
13	SP_VP275_13	Truss head tapping screw ST4X12
14	SP_VP275_14	Cross recessed oval head tapping screw ST4x12
15	SP_VP275_15	Main frame
16	SP_VP275_16	Hexagon socket oval head bolt M8x40
17	SP_VP275_17	Washer D8
18	SP_VP275_18	Nylon nut M8
19	SP_VP275_19	Plastic bushing
20	SP_VP275_20	Driving shafting
21	SP_VP275_21	Bracket plate
22	SP_VP275_22	Hexagon socket oval head bolt M6x25
23	SP_VP275_23	Motor belt
24	SP_VP275_24	Motor
25	SP_VP275_25	Cross recessed truss head screw M6x10
26	SP_VP275_26	Base frame
27	SP_VP275_27	Base housing
28	SP_VP275_28	Truss head screw M5x16
29	SP_VP275_29	Carrying handle
30	SP_VP275_30	Foot pad
31	SP_VP275_31	Electric controller
32	SP_VP275_32	Transportation wheel
33	SP_VP275_33	Wheel shaft
34	SP_VP275_34	Cross recessed oval head tapping screw ST4x16
35	SP_VP275_35	Resistance band plate
36	SP_VP275_36	Power switch
37	SP_VP275_37	Cross recessed truss head screw M5x8
38	SP_VP275_38	Hexagon socket oval head bolt M6x20
39	SP_VP275_39	PCB bracket
40	SP_VP275_40	Power cord
41	SP_VP275_41	Resistance band
42	SP_VP275_42	Remote controller