

# EXPLOSION-DRAWING / SPAREPARTS-OVERVIEW

## EXPLOSIONSZEICHNUNG / ERSATZTEILLISTE

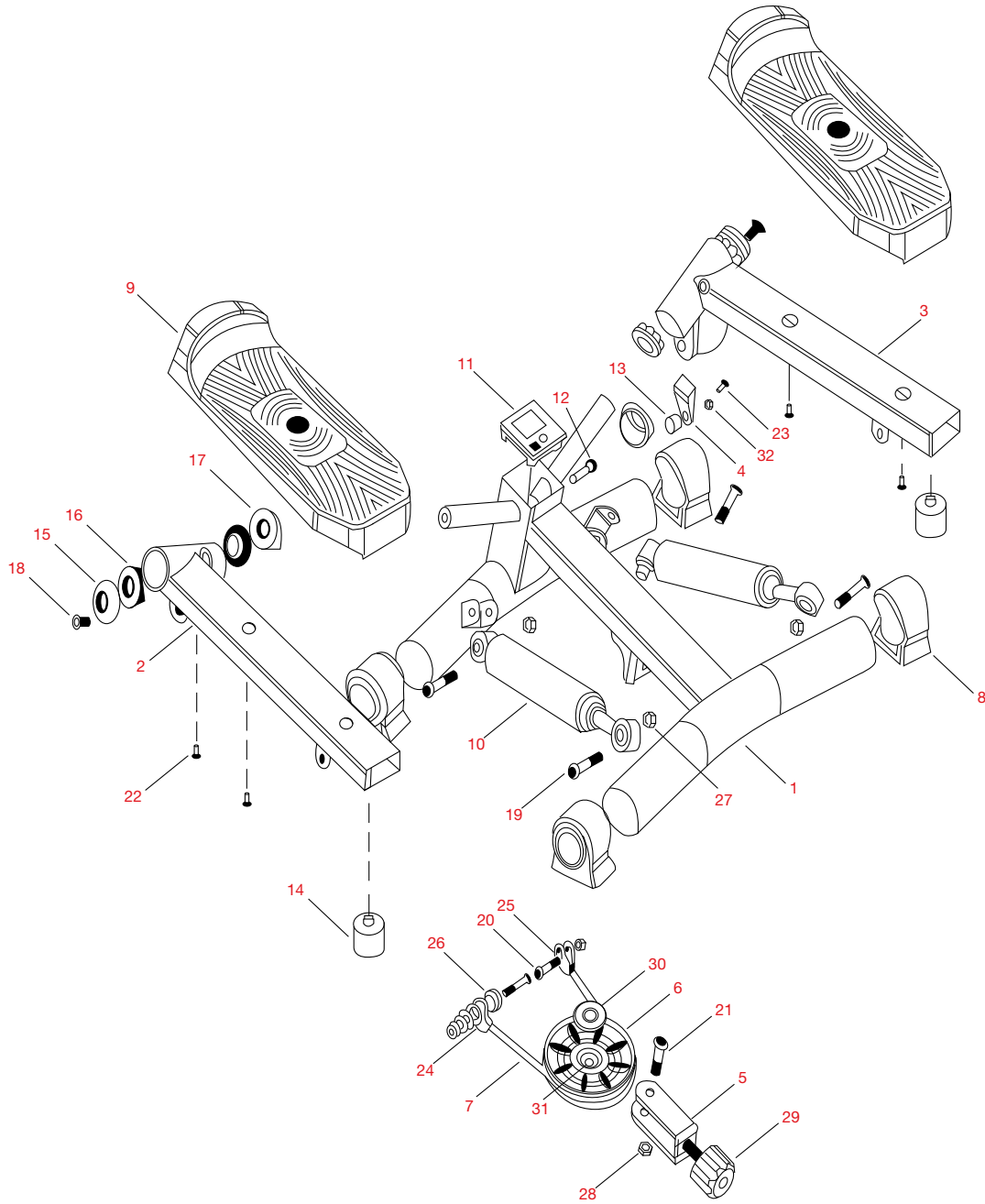

**SPORTSTECH**

**STEPPER STX300**

Number in explosion drawing	Item number	Description
1	SP_STX300_01	Main frame
2	SP_STX300_02	Left pedal stationary weldment
3	SP_STX300_03	Right pedal stationary weldment
4	SP_STX300_04	Magnet fixing plate
5	SP_STX300_05	Pulley stationary weldment
6	SP_STX300_06	Pulley
7	SP_STX300_07	Cable
8	SP_STX300_08	Foot tube cover
9	SP_STX300_09	Pedal
10	SP_STX300_10	Hydraulic lever
11	SP_STX300_11	Electronic meter
12	SP_STX300_12	Magnetic induction contact
13	SP_STX300_13	Magnet
14	SP_STX300_14	Cushion gasket
15	SP_STX300_15	Semi-circle end cover
16	SP_STX300_16	Inner axle sleeve
17	SP_STX300_17	Oblique axle sleeve
18	SP_STX300_18	Cup hexagonal screw M8x15

Number in explosion drawing	Item number	Description
19	SP_STX300_19	Cup head inner hexagon screw M8x40
20	SP_STX300_20	Cup head inner hexagon screw M8x30
21	SP_STX300_21	Cup head inner hexagon screw M10x40
22	SP_STX300_22	Flat-head Phillips head screw thumb head self-tapping screw D4x12
23	SP_STX300_23	Flat round head with hexagonal screws M5x10
24	SP_STX300_24	T-type casing D8xD10.5xD14.3x7.2
25	SP_STX300_25	Flat washer D8
26	SP_STX300_26	Flat plastic gasket D8
27	SP_STX300_27	Locknut M8
28	SP_STX300_28	Locknut M10
29	SP_STX300_29	Knob cap
30	SP_STX300_30	Bearing fixing piece
31	SP_STX300_31	Bearing
32	SP_STX300_32	Locknut M5
not in drawing	SP_STX300_33	Exercise Band
not in drawing	SP_STX300_Carton	Carton for A quality
not in drawing	SP_STX300_Carton_BW	Carton for B quality
not in drawing	SP_STX300_Manual	Manual