

EXPLOSION-DRAWING / SPAREPARTS-OVERVIEW

EXPLOSIONSZEICHNUNG / ERSATZTEILLISTE

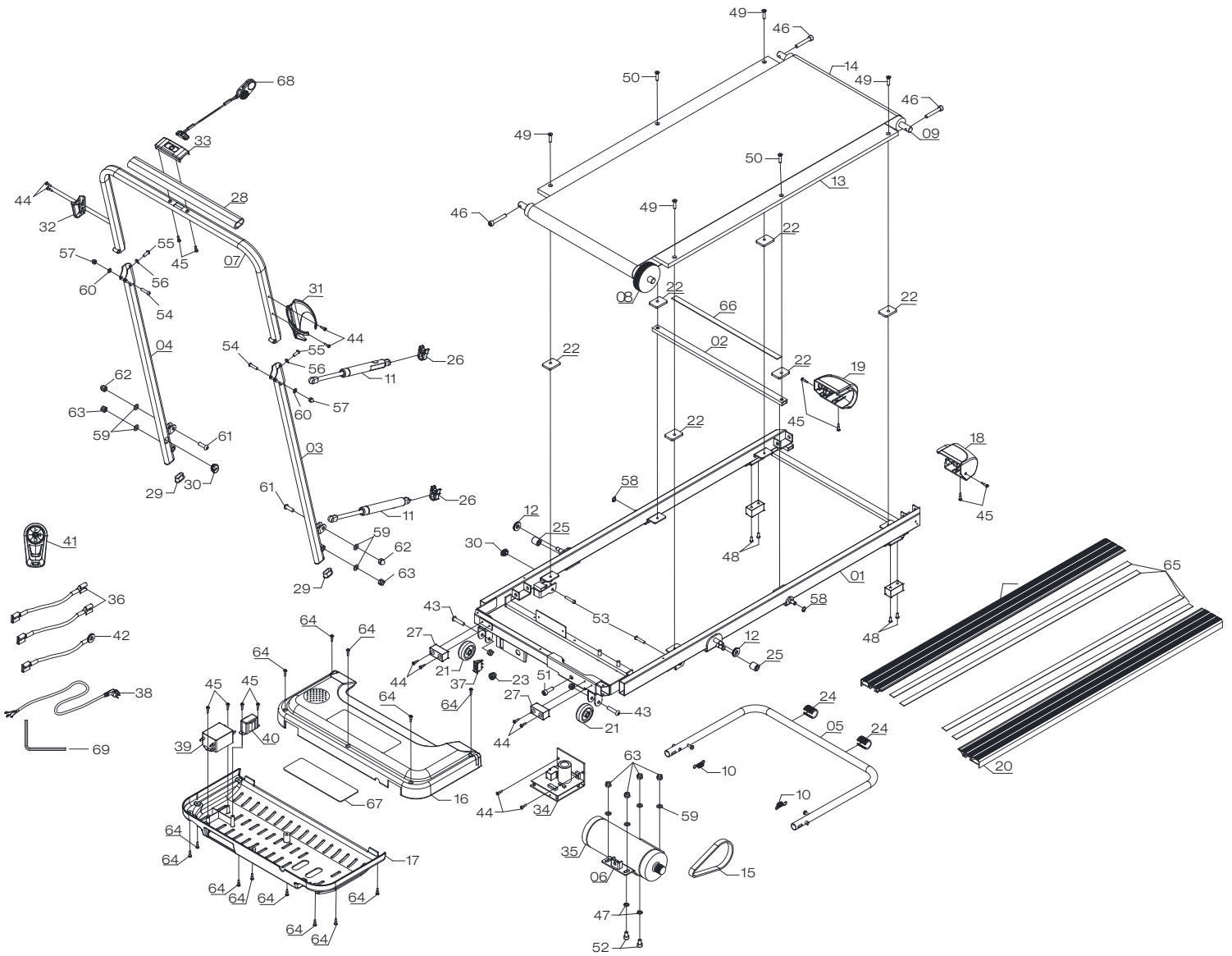

Treadmill DFT100

Laufband DFT100

Number in explosion drawing	Item number	Description
1	SP_DFT100_01	Main frame
2	SP_DFT100_02	Strengthen tube
3	SP_DFT100_03	Upright right
4	SP_DFT100_04	Upright Left
5	SP_DFT100_05	Rear support frame
6	SP_DFT100_06	Motor frame
7	SP_DFT100_07	Handlebar tube
8	SP_DFT100_08	Front roller set
9	SP_DFT100_09	Rear roller set
10	SP_DFT100_10	Spring
11	SP_DFT100_11	Cylinder
12	SP_DFT100_12	Washer
13	SP_DFT100_13	Running board
14	SP_DFT100_14	Running belt
15	SP_DFT100_15	Belt
16	SP_DFT100_16	UP motor cover
17	SP_DFT100_17	Down motor cover
18	SP_DFT100_18	End cap left
19	SP_DFT100_19	End cap right
20	SP_DFT100_20	Side rails
21	SP_DFT100_21	Transport wheel
22	SP_DFT100_22	Rubber cushion
23	SP_DFT100_23	Power cord
24	SP_DFT100_24	C tube cap
25	SP_DFT100_25	Absorber
26	SP_DFT100_26	Absorber
27	SP_DFT100_27	Front cushion
28	SP_DFT100_28	Handlebar
29	SP_DFT100_29	Tube cap
30	SP_DFT100_30	Wire cap
31	SP_DFT100_31	Bottle holder
32	SP_DFT100_32	Remote controller frame
33	SP_DFT100_33	Safety key
34	SP_DFT100_34	Controller
35	SP_DFT100_35	DC motor
36	SP_DFT100_36	AC single wire
37	SP_DFT100_37	Switch

Numer in Explosionszeichnung	Artikelnummer	Beschreibung
38	SP_DFT100_38	Power cord
39	SP_DFT100_39	Filter
40	SP_DFT100_40	Remote
41	SP_DFT100_41	Battery
42	SP_DFT100_42	Ground wire
43	SP_DFT100_43	Screw
44	SP_DFT100_44	Screw
45	SP_DFT100_45	Screw
46	SP_DFT100_46	Screw
47	SP_DFT100_47	Spring washer
48	SP_DFT100_48	Screw
49	SP_DFT100_49	Screw
50	SP_DFT100_50	Screw
51	SP_DFT100_51	Screw
52	SP_DFT100_52	Screw
53	SP_DFT100_53	Screw
54	SP_DFT100_54	Screw
55	SP_DFT100_55	Screw
56	SP_DFT100_56	Curved washer
57	SP_DFT100_57	Nut
58	SP_DFT100_58	Snap ring
59	SP_DFT100_59	Washer
60	SP_DFT100_60	Washer
61	SP_DFT100_61	Screw
62	SP_DFT100_62	Nut
63	SP_DFT100_63	Nut
64	SP_DFT100_64	Screw
65	SP_DFT100_65	Foam glue 1
66	SP_DFT100_66	Foam glue 2
67	SP_DFT100_67	Sticker
68	SP_DFT100_68	Safety key
69	SP_DFT100_69	Wrench
not in drawing	SP_DFT100_70	Wrench
not in drawing	SP_DFT100_Screw set	Screw set
not in drawing	SP_DFT100_Manual	Manual
not in drawing	SP_DFT100_Carton_Top	Carton
not in drawing	SP_DFT100_Carton_Bottom	Carton