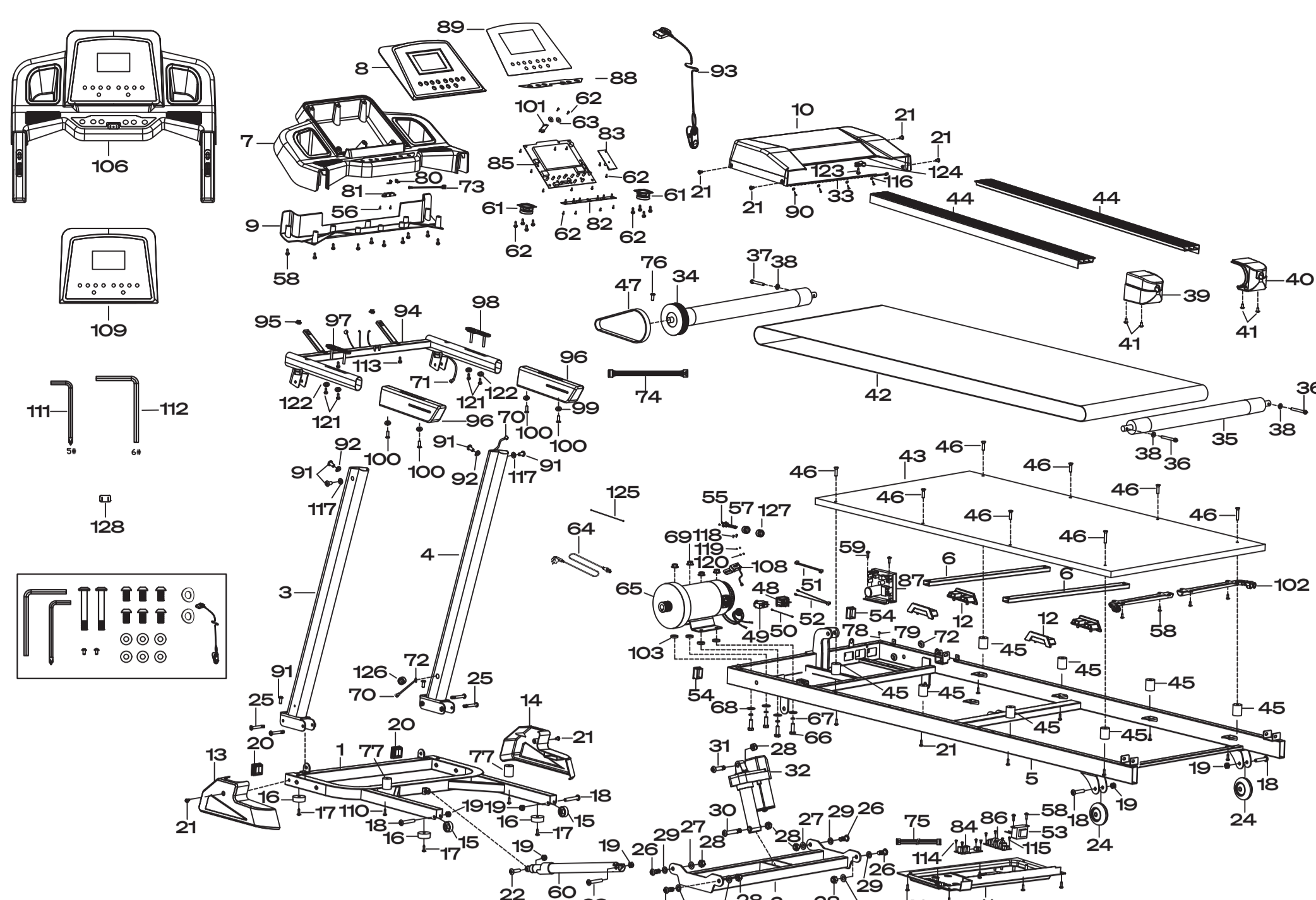

Treadmill F31s

EXPLOSION-DRAWING / SPAREPARTS-OVERVIEW
EXPLOSIONSZEICHNUNG / ERSATZTEILLISTE

No. in explosion drawing	Item number	Description
1	SP_F31s_O1	Base frame
2	SP_F31s_O2	Incline frame
3	SP_F31s_O3	Left supporting tube
4	SP_F31s_O4	Right supporting tube
6	SP_F31s_O6	Reinforced tube
7	SP_F31s_O7	Console housing
8	SP_F31s_O8	Console upper cover
9	SP_F31s_O9	Console bottom cover
10	SP_F31s_O10	Upper motor cover
11	SP_F31s_O11	Bottom motor cover
12	SP_F31s_O12	Cushion
13	SP_F31s_O13	Left base frame cover
14	SP_F31s_O14	Right base frame cover
15	SP_F31s_O15	Front transportation wheel
16	SP_F31s_O16	Foot pad
17	SP_F31s_O17	Cross recess screw M6 x 16
18	SP_F31s_O18	Hexagon socket oval head bolt M8x40
19	SP_F31s_O19	Nylon nut M8
20	SP_F31s_O20	Base frame end cap 40x40mm
21	SP_F31s_O21	Truss head screw M5 x 10
22	SP_F31s_O22	Hexagon socket oval head bolt M8x30
23	SP_F31s_O23	Hexagon socket oval head bolt M8x44
24	SP_F31s_O24	Rear transportation wheel
25	SP_F31s_O25	Hexagon socket oval head bolt M8x60
26	SP_F31s_O26	Hexagon socket oval head bolt M10x25
27	SP_F31s_O27	Washer D10
28	SP_F31s_O28	Nylon nut M10
29	SP_F31s_O29	Plastic washer
30	SP_F31s_O30	Hexagon socket oval head bolt M10x65
31	SP_F31s_O31	Hexagon socket oval head bolt M10x40
32	SP_F31s_O32	Incline motor
33	SP_F31s_O33	Motor cover led board
34	SP_F31s_O34	Front roller
35	SP_F31s_O35	Rear roller
36	SP_F31s_O36	Hexagon socket oval head bolt M8x55
37	SP_F31s_O37	Hexagon socket oval head bolt M8x45
38	SP_F31s_O38	Washer D8
39	SP_F31s_O39	Left end cover
40	SP_F31s_O40	Right end cover
41	SP_F31s_O41	Cross recessed oval head tapping screw ST4x16
42	SP_F31s_O42	Running belt
43	SP_F31s_O43	Running board
44	SP_F31s_O44	Side rail
45	SP_F31s_O45	Running board cushion
46	SP_F31s_O46	Cross recessed oval head screw M5 x 25
47	SP_F31s_O47	Motor belt
48	SP_F31s_O48	Power switch
49	SP_F31s_O49	Overload button
50	SP_F31s_O50	Wire for overload button
51	SP_F31s_O51	Wire for power switch
52	SP_F31s_O52	Wire for EMI
53	SP_F31s_O53	Choke
54	SP_F31s_O54	Main frame end cap 30x40mm
55	SP_F31s_O55	Truss head screw M3 x 8
56	SP_F31s_O56	Cross recessed truss head tapping screw ST3x12
57	SP_F31s_O57	Power socket
58	SP_F31s_O58	Cross recessed truss head tapping screw ST4x12
59	SP_F31s_O59	Truss head screw M5 x 20
60	SP_F31s_O60	Gas spring
61	SP_F31s_O61	Speaker
62	SP_F31s_O62	Cross recessed oval head tapping screw ST3x8
63	SP_F31s_O63	Washer D3
64	SP_F31s_O64	Power cord
65	SP_F31s_O65	Motor
66	SP_F31s_O66	Hexagon socket oval head bolt M8x20
67	SP_F31s_O67	Spring washer D8
68	SP_F31s_O68	Washer D8
69	SP_F31s_O69	Flange nut M8
70	SP_F31s_O70	Main control cable
71	SP_F31s_O71	Display control cable
72	SP_F31s_O72	Cable grommet
73	SP_F31s_O73	Wire for safety key
74	SP_F31s_O74	Wire for key board
75	SP_F31s_O75	Wire for led control board
76	SP_F31s_O76	Hexagon socket oval head bolt M8x25
77	SP_F31s_O77	Rubber stopper
78	SP_F31s_O78	Truss head tapping screw M4x8
79	SP_F31s_O79	Spring washer D4
80	SP_F31s_O80	Magnetic ring
81	SP_F31s_O81	Safety key bracket
82	SP_F31s_O82	Key board
83	SP_F31s_O83	Bluetooth music module
84	SP_F31s_O84	LED control board
85	SP_F31s_O85	Display board
86	SP_F31s_O86	EMI filter
87	SP_F31s_O87	Electric controller
88	SP_F31s_O88	Display overlay
89	SP_F31s_O89	Key board overlay
90	SP_F31s_O90	Cross recessed oval head tapping screw ST3x12
91	SP_F31s_O91	Hexagon socket oval head bolt M8x16
92	SP_F31s_O92	Curve washer D8
93	SP_F31s_O93	Safety key
95	SP_F31s_O95	End cap 10x20mm
96	SP_F31s_O96	Handlebar foam
97	SP_F31s_O97	Left handle control kit
98	SP_F31s_O98	Right handle control kit
99	SP_F31s_O99	Washer D4
100	SP_F31s_O100	Cross recessed oval head tapping screw ST4x30
101	SP_F31s_O101	Wireless pulse module
102	SP_F31s_O102	Right lubrication tube
103	SP_F31s_O103	Footpad of motor
104	SP_F31s_O104	Left lubrication tube
105	SP_F31s_O105	Small foot pad
106	SP_F31s_O106	Console set
108	SP_F31s_O108	Sensor for motor
109	SP_F31s_O109	Display set
110	SP_F31s_O110	Cross recess screw M5 x 10
111	SP_F31s_O111	Hex wrench 5 mm (T 30) + Screw driver
112	SP_F31s_O112	Hex wrench 6 mm (T 45)
113	SP_F31s_O113	Cross recess tapping screw 4 x 11
114	SP_F31s_O114	Cross recess tapping screw 3 x 7
115	SP_F31s_O115	Cross recess tapping screw 3 x 8
116	SP_F31s_O116	Fibre washer 3 x 6
117	SP_F31s_O117	Washer M8 x 16
118	SP_F31s_O118	Cross recess screw M5 x 7
119	SP_F31s_O119	Spring washer M5 x 8
120	SP_F31s_O120	Washer M5 x 10
121	SP_F31s_O121	Cross recess tapping screw 4 x 16
122	SP_F31s_O122	Washer 5 x 15
123	SP_F31s_O123	Cross recess tapping screw 3 x 8
124	SP_F31s_O124	Cable holder
125	SP_F31s_O125	Ground wire
126	SP_F31s_O126	Ferrite ring for main control cable
127	SP_F31s_O127	Ferrite ring for power socket
128	SP_F31s_O128	Sticker for safety key socket
Not in drawing	SP_F31s_Manual	Manual
Screw set	SP_F31s_Screw set	Screw and tool set